

MICHIGAN JOURNAL OF INTERNATIONAL LAW



**THE STATE AND THE POST-COLD WAR  
REFUGEE REGIME: NEW MODELS,  
NEW QUESTIONS**

*Julie Mertus*

Vol. 20, No. 1

Fall 1998

**THE STATE AND THE POST-COLD WAR  
REFUGEE REGIME:  
NEW MODELS, NEW QUESTIONS**

*Julie Mertus\**

A.	<i>The Post-Cold War Refugee Regime: A Shift Away from the Statist Paradigm</i> .....	64
1.	Outlining the Cold-War, Statist Model .....	64
2.	The Shift Away from the State .....	66
B.	<i>The Post-Cold War Refugee Regime: A Soured Statist Paradigm</i> .....	74
1.	State Refusal to Grant Asylum .....	76
2.	The International Community's Move from Protection to Containment .....	79
3.	From Durable Solutions to a Temporary Arrangement or Repatriation .....	82
	CONCLUSION: NEW QUESTIONS .....	85

The refugee regime<sup>1</sup> has undergone a radical transformation since the end of the Cold War, dramatically altering opportunities and challenges for the realization of human rights. Some of the changes are related to the Cold War itself. Others grow out of the contemporaneous process of globalization<sup>2</sup> and individuation,<sup>3</sup> twin phenomena that radi-

---

\* J.D. Yale Law School 1988, Assistant Professor, Ohio Northern University, Claude W. Pettit College of Law. Julie Mertus wishes to thank Deborah Anker, Pamela Goldberg, Todd Howland, and Thomas Weiss for their suggestions; Katherine Guernsey and Barbara Wilson for their research assistance; and the Harvard Law School Human Rights Program and the Harvard Center for International Affairs for supporting this work. A monograph by the author applying this model, "Assistance and Protection: The Gender Connection," will be published in 1999 by the Humanitarianism and War Project, Watson Institute for International Affairs, Brown University.

1. The term "refugee regime" at one time referred only to those laws, policies and practices set up to deal with "refugees" as defined by the 1951 Convention on Refugees. As explained below, the regime has become enlarged in scope to cover all those uprooted in war, including "war victims" (all victims regardless of movement) and "displaced people" (those who are displaced from their homes but who remain within their state of origin) and, in addition, the regime now includes many less formal systems and actors that interact with and/or complement the original systems and mechanisms. As used in this essay, "refugee regime" refers to the second, broader definition. Unless otherwise noted, the term "refugee" is used throughout to apply to refugees and displaced people. See James C. Hathaway, *A Reconsideration of the Underlying Premise of Refugee Law*, 31 HARV. INT'L L. J. 129 (1990).

2. Zdravko Mlinar has identified five dimensions of globalization: (1) globalization as increasing interdependence at the world level, wherein the activities of people in specific

cally transform the statist paradigm and the kinds of challenges encountered by those concerned with the human rights of refugees. These developments are complex. We can say that the shift from a Cold War refugee paradigm<sup>4</sup> to a post-Cold War paradigm has occurred during a time of globalization and individuation. At the same time, however, globalization and individuation have accelerated as the Cold War has deflated. Delineating cause and effect and pinpointing the exact moment of intersections would be an impossible task. We can, however, identify the attributes of this paradigm shift and, within it, locate challenges to the statist paradigm. Through this analysis, we can better understand the field in which human rights and refugee advocates operate and fashion solutions to meet today's problems.

The statist paradigm and its critique have long been central to the agenda of many international law and human rights scholars.<sup>5</sup> The dominant approach to international organization, viewing states as the primary unit of analysis and sovereignty as the primary measure safe-

---

areas have repercussions that go beyond local, regional or national borders; (2) globalization as the expansion of domination and dependence, that is "an inter-connectedness on the global scale, in which *radial* rather than *lateral links* predominate"; (3) globalization as homogenization of the world wherein "instead of differences among territorial units which were mutually exclusive, there is now a *uniformity*"; (4) globalization as diversification within "territorial communities" wherein "the level of globalization can be measured by the extent to which narrow territorial units are open and permit access to the wealth of diversity of the world as a whole"; (5) globalization as a means of surmounting temporal discontinuities through "(a) connectedness of the asynchronous rhythms of different activities and (b) temporal inclusiveness resulting from the functioning of particular services to global space frames." Zdravko Mlinar, *Individuation and Globalization; The Transformation of Territorial Social Organization*, in *GLOBALIZATION AND TERRITORIAL IDENTITIES* 15, 20-22 (Zdravko Mlinar ed., 1992); see also Richard Falk, *Regionalism and World Order after the Cold War*, 1995 *ST. LOUIS-WARSAW TRANSATLANTIC L. J.* 71-88.

3. By individuation, I refer to "the processes of increasing the autonomy and distinctiveness of the actors at both the collective and individual levels." Mlinar, *supra* note 2, at 15. Mlinar identifies the dimensions of individuation as: (1) the weakening of predetermination on the basis of origin; (2) the weakening of determination on the basis of territory; (3) increasing the diversity of "time-space paths" (that is, not being limited to the role and position of individuals in space at a specific moment in time); (4) increasing control and decrease of (random) intrusions from the external environment (wherein actors assert greater control over the impulses from the environment); and (5) increased authenticity of the assertion of identity (more direct assertion of identity without the use of intermediaries or representatives). *Id.*

4. The Cold War paradigm is similar to, but distinct from, the colonialist paradigm. For example, colonialist donors may be more influenced by their desire to perpetuate their culture on the other, see Cecilia Ruthstrom-Ruin, *BEYOND EUROPE: THE GLOBALIZATION OF REFUGEE AID* 132-135 (Bengt Ankarloo, Sven Tägil, et. al. eds., 1993) (discussing British and French aid to African colonies). This essay will not equate the two, but will instead leave discussion of the colonialist and post-colonialist refugee paradigms to another day.

5. With respect to security issues, the state is generally viewed as central. See G. Sorensen, *Individual Security and National Security: The State Remains the Principle Problem*, 27(4) *SECURITY DIALOGUE* 371 (1996).

guarding state action within its territories,<sup>6</sup> has been re-examined, demythologized, and de-constructed.<sup>7</sup> This essay adds to the debate through the examination of the refugee regime, an area in which states and notions of sovereignty have always played an important role. It asks two converse questions. First, how does the changed role of the state in today's "globalized"<sup>8</sup> society affected the refugee regime? Second, how does today's refugee regime re-figure the role of the state? This article charts the paradigm shift in the refugee regime in the context of these questions.

My thesis is that within the refugee regime the move away from states and adherence to states are two sides of the same coin. To some degree the new refugee regime reflects the trend away from both the state and strict notions of sovereignty. Nonetheless, the new regime also exposes the staying power of the statist paradigm. In many respects, the role of states has indeed been altered, but states have retained their role as important and often essential actors. While other observers have commented on specific geographic or thematic changes in the refugee regime,<sup>9</sup> this essay attempts to place the paradigm shift within a conceptual framework, and from this framework asks new questions about the nature and future direction of refugee law and policy. These questions must be answered if we are to address protection and assistance concerns of refugees.

---

6. See, e.g., KENNETH N. WALTZ, *THEORY OF INTERNATIONAL POLITICS* (1979).

7. See, e.g., LUIS E. LUGO, *SOVEREIGNTY AT THE CROSSROADS?* (1996); BEYOND WEST-PHALIA? *STATE SOVEREIGNTY AND INTERNATIONAL INTERVENTION* (Gene M. Lyons & Michael Mastanduno eds., 1995); *Conference on Changing Notions of Sovereignty and the Role of Private Actors in International Law*, 9 *AM. U. J. INT'L L. & POL'Y* 1 (1993); Christopher H. Schreuer, *The Waning of the Sovereign State: Towards a New Paradigm for International Law?*, 4 *EUR. J. INT'L L.* 447 (1993); Jarat Chopra & Thomas G. Weiss, *Sovereignty Is No Longer Sacrosanct*, 6 *ETHICS & INT'L AFF.* 95, 95-117 (1992); Martti Koskenniemi, *The Future of Statehood*, 32 *HARV. INT'L L. J.* 397 (1991); W. Michael Reisman, *Sovereignty and Human Rights in Contemporary International Law*, 84 *AM. J. INT'L L.* 866 (1990); *CONTENTING SOVEREIGNTIES: REDEFINING POLITICAL COMMUNITY* (R.B.J. Walker & S.H. Medlovitz eds., 1990).

8. For some of the attributes of globalization, see *infra* note \_\_\_\_ and text at \_\_\_\_.

9. See, e.g., The Office of the United Nations High Commissioner for Refugees (UNHCR), *THE STATE OF THE WORLD'S REFUGEES: A HUMANITARIAN APPEAL, 1997-1998* (Oxford University Press 1997).

FIGURE ONE: COLD-WAR PARADIGM

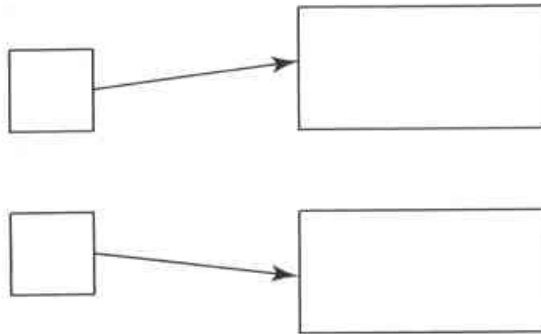
*Sending States*

- the uprooted leave their country of origin
- refugees leave in order to receive asylum
- the uprooted go to states with which they have ideological affiliations (and to nearby safe areas)

*Receiving States*

- receiving states consider those entering for asylum (and temporary safe haven)
- aid is delivered to refugees in host countries or in asylum countries
- cold-war strategy gives receiving states an incentive to accept those with whom they have ideological and geopolitical affiliations/interests
- Although NGOs and GOs may facilitate this process, states are the main actors

FIGURE TWO: THE NEW REFUGEE REGIME

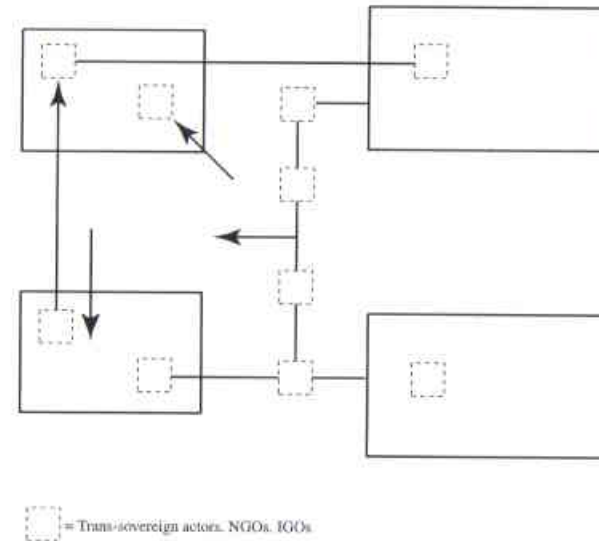
*Sending States*

- the uprooted remain within as internally displaced
- those that cross state lines remain in a nearby state (usually a traditionally "sending-state")
- aid is delivered within the country of origin and in safe areas near the borders

*Receiving States*

- measures are undertaken to contain refugee flows and to restrict asylum (and to offer temporary safe haven)
- receiving states (which increasingly are not countries of traditional asylum,) work together and trans-sovereign actors—NGOs, and IGOs—to deliver humanitarian aid and development support.
- cross linkages appear between NGOs in receiving and sending states

### A. *The Post-Cold War Refugee Regime: A Shift Away from the Statist Paradigm*

#### 1. Outlining the Cold-War, Statist Model

The classic, Cold War refugee regime was structured along statist lines. It featured three primary types of actors: sending states, receiving states, and refugees. (Figure One represents a simplified model of refugee and aid flows, and is further developed in the first column of Chart A at the end of the essay). Under this model, state boundaries were tied to the very definition of who was worthy of aid and protection.<sup>10</sup> Further, the doors of receiving countries were to be open to "refugees," those persons outside their country of nationality who have a well founded fear of persecution on account of race, religion, nationality, membership in a particular social group or political opinion, as defined by the 1951 United Nations Convention and its 1967 Protocol.<sup>11</sup> Those who did not fit the definition of persecution, who did not fall within the limited persecution grounds, and who were uprooted<sup>12</sup> without having crossed state boundaries—the internally displaced—had no recourse to international legal protections and, for the most part, were denied any assistance.<sup>13</sup>

The traditional approach to refugees was "reactive in the sense that United Nations bodies, specifically the Office of the United Nations High Commissioner for Refugees ("UNHCR"), became interested in a person or population only when they had become displaced, crossed a border and sought asylum in another state."<sup>14</sup> Action depended upon the existence of an exiled refugee population desiring resettlement in another state. Sending states were usually paired with receiving states based on ideological and geopolitical interests. Often the cause of uprootedness was linked directly or indirectly to Cold War struggles or, at

10. One of the best explanations of the development of this definition is found in ARISTIDE R. ZOLBERG ET AL., *ESCAPE FROM VIOLENCE: CONFLICT AND THE REFUGEE CRISIS IN THE DEVELOPING WORLD* 3-29 (1989).

11. Convention Relating to the Status of Refugees, July 28, 1951, *entered into force* April 22, 1954, 189 U.N.T.S. 50; *see also* Guy S. Goodwin-Gill, *Asylum: The Law and Politics of Change*, 7 INT'L J. REFUGEE L. 1 (1995).

12. This essay uses the term "uprooted" to refer to all people who are forced from their homes or otherwise removed or "disrupted" during war. Thus, "uprooted" is a more inclusive word than the legal term, "refugee."

13. For a review of the law of refugee status, *see, for example*, JAMES C. HATHAWAY, *THE LAW OF REFUGEE STATUS* (1991). Note that the most abundant group is nonconventional refugees who cross borders.

14. UNHCR, *THE STATE OF THE WORLD'S REFUGEES 1995: IN SEARCH OF SOLUTIONS* 30 (Oxford University Press 1995).

the very least, political strategic concerns formed a potential state donor's response to uprootedness. In this game, the U.S. was most concerned about its image with regard to the Soviet Union—enticing Soviet scientists and artists to the shores of the U.S., for example, was intended to make Soviet officials squirm.<sup>15</sup> Receiving states had a reason to open their doors: a desire to siphon off refugees from those states that supported the opposing ideology. Receiving countries could use population flows "to discredit both the government or country of origin and to bolster the image of countries granting them asylum."<sup>16</sup> In other situations, Cold Warriors could "take advantage of refugee movements by arming and training some of the people concerned and using them to destabilize the government within their homeland."<sup>17</sup>

In the Cold War era, the locus of aid to refugees was usually in the receiving country. There was considerable discussion of the human rights abuses and political ideology that purportedly forced the refugees to flee. Nonetheless, the "international community"<sup>18</sup> gave little thought to foreign aid designed to contain refugee flows, or to developing or reforming the sending country's infrastructure. Thus, the issue of the receiving government giving its "consent" simply did not arise.<sup>19</sup> The few Non-Governmental Organizations ("NGOs") that did exist played a limited role in the process, apart from carrying out their own government's concerns, and very few truly non-governmental links existed between citizens' organizations and NGOs in sending and receiving states. In short, aid of any type, including asylum, was linked to Cold War foreign policy concerns.<sup>20</sup>

15. Boldizsar Nagy, *Changing Trends, Enduring Questions Regarding Refugee Law in Central Europe*, in ISTVAN POGANY, *HUMAN RIGHTS IN EASTERN EUROPE* 185, 191 n.17 (1995) (citing 1953 National Security Council paper which stated explicitly that it was American foreign policy "to encourage defection of all USSR nationals as well as of 'key' personnel from the satellite countries" as this would inflict a "psychological blow on Communism").

16. UNHCR, *supra* note 14, at 37.

17. *Id.* (citing the examples of the Nicaraguan Contras in Honduras, the Afghan mujahideen in Pakistan, and the Namibian exiles in Angola).

18. Throughout this essay I use "international community" reluctantly as it has both no meaning and the most precise meaning. International community refers to whatever the reader thinks is the community that acts internationally. When speaking about the international community's concern about human rights, for example, a western reader might call to mind western powers debating western concepts.

19. *See, e.g.*, Christine Gray, *Host State Consent and UN Peacekeeping in Yugoslavia*, 7 DUKE J. COMP. & INT'L L. (1996).

20. A review of the aid in this era is out of the scope of this essay. *See generally* JOAN M. NELSON, *AID, INFLUENCE AND FOREIGN POLICY* (1968); G. Ohlin, *The Evolution of Aid Doctrine, in FOREIGN AID: SELECTED READINGS* (Jagdish Bhagwati & Richard S. Eckaus eds., 1970); ROBERT S. WALTERS, *AMERICAN AND SOVIET AID: A COMPARATIVE ANALYSIS* (1970).

## 2. The Shift Away from the State

The post-Cold War refugee regime illustrates a complicated shift away from this state-centric model. (See Figure Two, above, and the second column on Chart A). The clarity of Cold War rhetoric now dissolved, the regime has spun into an identity crisis. "In the post-cold war years, as in the period after the first and second world wars, forced population displacements have proven to be a prominent consequence of the demise of old ideologies, the collapse of existing empires and the formation of new states."<sup>21</sup> Today, refugees are often victims of violence or natural disasters, not ideological persecution. Would-be receiving states and donors can no longer tell whom they are supposed to help based on clear-cut ideological grounds.<sup>22</sup> Sending and receiving states thus are no longer coupled together, and formerly opposing Cold Warriors even find themselves on the same side of a donor equation.<sup>23</sup> Prejudice—such as racism and nativism—now factors more heavily into asylum decisions than it did during the Cold War.<sup>24</sup> Receiving states talk less about the human rights of the uprooted and more about their own rights. For instance, they talk about their right to protect their own culture and standard of living from the foreign intruders<sup>25</sup> and about the larger "security dimension."<sup>26</sup>

Large-scale displacements of people are increasingly perceived as presenting regional and international security risks. In Bosnia, for example, return of refugees under the Dayton Peace Accord is considered essential to long-term peace and stability in the Balkans.<sup>27</sup> Similarly, the UNHCR has recognized that "it is impossible to understand the dynamics and dimensions of the current crisis [in the Great Lakes region of

21. UNHCR, *supra* note 9, at 1.

22. For an examination of changes in U.S. policy due to the end of the Cold War, see Davalene Cooper, Note, *Promised Land or Land of Broken Promises? Political Asylum in the United States*, 76 KY. L.J. 923 (1988).

23. See, e.g., Claire Messina, *From Migrants to Refugees: Russian, Soviet and Post-Soviet Migration*, 6 INT'L J. REFUGEE L. 620 (1994).

24. See, e.g., BILL ONG HING, *TO BE AN AMERICAN: CULTURAL PLURALISM AND THE RHETORIC OF ASSIMILATION* (1997); *IMMIGRANTS OUT! THE NEW NATIVISM AND THE ANTI-IMMIGRANT IMPULSE IN THE UNITED STATES* (Juan F. Perea ed., 1997); DALE T. KNOBEL, *AMERICA FOR THE AMERICANS: THE NATIVIST MOVEMENT IN THE UNITED STATES* (1996); WALTER BENN MICHAELS, *OUR AMERICA: NATIVISM, MODERNISM, AND PLURALISM* (1995); *NATIVISM, DISCRIMINATION, AND IMAGES OF IMMIGRANT* (George E. Pozzetta ed., 1991).

25. See, e.g., Deborah J. Bartz, *The United States HIV Exclusion: Endangering Refugees' Human Rights*, 17 HAMLINE L. REV. 155 (1993); Sarah N. Qureshi, *Global Ostracism of HIV-Positive Aliens: International Restrictions Barring HIV-Positive Aliens*, 19 MD. J. INT'L L. & TRADE 81 (1995).

26. See ADAM ROBERTS, *HUMANITARIAN ACTION IN WAR* (1996).

27. UNHCR, *supra* note 9, at 3.

Africa] without reference to the long history of forced displacement in the region."<sup>28</sup>

The crossing of international borders is not the reality for the vast number of people who require protection from armed conflict today who remain within state borders but are deemed to be internally displaced populations (IDPs).<sup>29</sup> The internally displaced present new protection and assistance dilemmas to human rights and humanitarian organizations.<sup>30</sup> While the 1951 Refugee Convention and its protocol may protect those who cross state boundaries, no international conventions exist to protect displaced persons or those otherwise imperiled by war and, thus, this latter group of refugees is more susceptible to the whims of individual states.<sup>31</sup> Moreover, in the case of internally displaced people, the very government that caused the displacement often has the primary responsibility for their protection, thus complicating access and provision of protection and assistance.<sup>32</sup> As Roberta Cohen has observed:

Often [the internally displaced] are caught up in internal conflicts between their governments and opposing forces. Some of the highest mortality rates ever recorded during humanitarian emergencies have come from situations involving internally displaced persons. There is . . . no one international organization with responsibility for protection and assistance to the internally displaced.<sup>33</sup>

Encampments of internally displaced people fall prey to direct physical abuse from domestic military and paramilitary troops. For example, military forces slaughtered thousands of internally displaced people at the Kibeho camp in Rwanda, in an effort to close the camps.<sup>34</sup> International laws and policies utterly failed to provide timely protection;

28. *Id.*

29. See generally FRANCIS DENG & ROBERTA COHEN, *MASSES IN FLIGHT: THE GLOBAL CRISIS OF INTERNAL DISPLACEMENT* (1988).

30. See Humanitarianism and War Project, *Protecting Human Rights in Complex Emergencies* (forthcoming in 1999) (on file with author).

31. See Arthur Helton, *Refugee Protection Under International Law*, 1989 A.L.I. 2 (1989).

32. See Elizabeth E. Ruddick, *The Continuing Constraint of Sovereignty: International Law, International Protection and the Internally Displaced*, 77 B.U. L. REV. 429 (1997).

33. ROBERTA COHEN, *REFUGEE AND INTERNALLY DISPLACED WOMEN: A DEVELOPMENT PERSPECTIVE* (1995).

34. See Joint Evaluation of the Emergency Assistance to Rwanda, *The International Response to Conflict and Genocide. Study 2: Early Warning and Conflict Management* (1996).

international organizations could only step in after the massacre to provide humanitarian assistance.<sup>35</sup>

Given today's population flows, donors are hard pressed to determine aid recipients simply by reference to those who cross state boundaries; the criteria for aid now pertain more to need than to state boundaries.<sup>36</sup> Amir Pasic and Thomas Weiss have observed this shift:

When the bounds of territory, authority, and identity—of borders, political arrangements, and ethnic or national solidarities— are both ambiguous and uncertain, they serve as poor guides for action. In other words, it is situations and not categories of victims that should be addressed. Those suffering should receive attention in proportion to their needs whether or not they have been displaced.<sup>37</sup>

Increasingly, at the Secretary General and/or the General Assembly of the United Nations' request, the UNHCR extends its mandate to displaced persons and to war victims under their "good offices" jurisdiction.<sup>38</sup> For example, forty percent of the UNHCR-aid recipients in the former Yugoslavia were classified as "war victims," not internally displaced or refugees.<sup>39</sup> Considering displaced people and war victims together, approximately eighty-five percent of the UNHCR's budget for the former Yugoslavia was allocated to populations outside its formal mandate.<sup>40</sup>

Thus, the locus of aid has changed. Now, the distribution of aid is largely within the country of origin or in a nearby state. The number of situations in which humanitarian aid may proceed with the state's consent is growing.<sup>41</sup> A state's arbitrary refusal to provide aid may be considered an *abus de droit* and may be insufficient to prevent the United Nations from acting.<sup>42</sup> In these cases, protection of the human rights of humanitarian workers and aid recipients is of heightened concern.

35. See S. KLEINE-AHLBRANDT, *THE PROTECTION GAP: THE INTERNATIONAL PROTECTION OF INTERNALLY DISPLACED PEOPLE: THE CASE OF RWANDA* (1996).

36. This is not to say that all who are in need receive aid. In Rwanda, for example, the people who stayed were in great need, but they received very little.

37. Thomas G. Weiss & Amir Pasic, *Reinventing UNHCR: Enterprising Humanitarians in the Former Yugoslavia, 1991-1995*, 3 *GLOBAL GOVERNANCE* 41, 44 (1997).

38. See Francis M. Deng, *Dealing with the Displaced: A Challenge to the International Community*, 1 *GLOBAL GOVERNANCE* 45, 45-48 (1995); Arthur C. Helton, *Displacement and Human Rights: Current Dilemmas in Refugee Protection*, 47 *J. INT'L AFF.* 379, 381-382 (1994).

39. Weiss & Pasic, *supra* note 37, at 47.

40. *Id.*

41. See Richard Plender, *The Legal Basis of International Jurisdiction to Act with Regard to the Internally Displaced*, 6 *INT'L J. REFUGEE L.* 345 (1994).

42. *Id.* at 356.

Paramilitary troops from the Caucasus to the Great Lakes have deliberately targeted international human rights and humanitarian personnel.<sup>43</sup> In some instances in today's intra-state warfare, intervention has proceeded regardless of state consent where either the Security Council authorizes it,<sup>44</sup> or no functioning government is firmly established.<sup>45</sup>

New actors complicate this picture. Leading roles are now played by actors which appear both above and below states—including NGOs, intergovernmental organizations (IGOs), private voluntary organizations (PVOs), and other governmental and non-governmental entities. The UNHCR often "subcontracts out" humanitarian services to these entities<sup>46</sup> and to coalitions led by major powers and/or deployed entirely by them.<sup>47</sup> NGOs play an increasingly important role in the delivery of humanitarian assistance. For example, NGOs channel about twenty-five percent of U.S. assistance.<sup>48</sup> "In net terms, NGOs now collectively transfer more resources to the South than the World Bank."<sup>49</sup>

The goals of NGOs differ greatly from states. And, as Richard Falk observes:

[T]he agents of humanitarian intervention are now often actors other than governments, especially transnational citizens associations, operating on a political logic that is shaped almost exclusively by moral considerations—largely an ethos of responsibility and solidarity—that is very different from the statist outlook that guides most governments when they are engaged in humanitarian missions.<sup>50</sup>

Although NGOs cannot obviate the need for the state, they may provide essential services and aid, and they "create conditions that facilitate the formation of international institutions" and "reinforce the

43. See Humanitarianism and War Project, *supra* note 30.

44. See Fernando R. Teson, *Collective Humanitarian Intervention*, 17 *MICH. J. INT'L L.* 323 (1996); David Wippman, *Military Intervention, Regional Organizations and Host-State Consent*, 7 *DUKE J. COMP. & INT'L L.* 209 (1996).

45. Intervention may also be permitted to protect human rights. See Thomas Weiss, *Intervention: Whither the United Nations?*, 17 *WASH. U. L.Q.* 106 (1994).

46. For an example of the UNHCR's use of a regional NGO, see Rachel Lostumbo, *Tibetan Refugees in Nepal: From Established Settlements to Forcible Repatriation*, 9 *Geo. IMMIGR. L.J.* 911 (1995).

47. Thomas G. Weiss, *Rekindling Hope on U.N. Humanitarian Intervention, in LEARNING FROM SOMALIA: THE LESSONS OF ARMED HUMANITARIAN INTERVENTION* 207 (Walter S. Clark & Jeffrey Herbst eds., 1997).

48. Lebn Gorenker & Thomas G. Weiss, *Pluralizing Global Governance: Analytical Approaches and Dimensions*, 16 *THIRD WORLD Q.* 365 (1995).

49. *Id.* at 37, quoting Mark Duffield, *NGOs, Disaster Relief and Asset Transfer in the Horn: Political Survival in a Permanent Emergency*, 24 *DEV. AND CHANGE* 140 (1993).

50. Richard Falk, *The Complexities of Humanitarian Intervention: A New World Order Challenge*, 17 *MICH. J. INT'L L.* 491, 499 (1996).

norms promoted by these institutions through public education as well as through organized attempts to hold states accountable to [them]. . . .<sup>51</sup> In this sense, NGOs can serve to promote human rights norms in the humanitarian sphere. Yet, NGOs are a wild card. For the most part, they are left free to operate unchecked by international law either because such laws do not apply to them,<sup>52</sup> or due to a lack of political will to hold NGOs accountable.<sup>53</sup> As a result, the record of NGOs on protecting, promoting, and following human rights norms in the refugee field is sketchy at best.

The cause of this uprooting has also changed in the post-Cold War Model, reflecting a further shift away from the state. As in the Cold War era, major refugee flows are "deeply rooted in the dominant geopolitical institutions of the global system and are directly or indirectly related to the conflict between the superpowers."<sup>54</sup> However, eruptions of violence are more likely to be internal than interstate,<sup>55</sup> involving competing power struggles divided by ethnic or national<sup>56</sup> loyalties. While conflicts

51. JANIE LEATHERMAN ET AL., INTERNATIONAL INSTITUTIONS AND TRANSNATIONAL SOCIAL MOVEMENT ORGANIZATIONS: CHALLENGING THE STATE IN A THREE-LEVEL GAME OF GLOBAL TRANSFORMATION, Working Paper Series 4 (South Bend, IN: Kroc Institute, Oct. 1993). At the same time, NGOs are also motivated by self-interest and, given that many NGOs are directly or indirectly state-funded, they usually will not move too far from a donor's perspective.

52. NGOs have not generally been regarded as subjects of international law, but this status is changing. See Stephen Hobe, *Global Challenges to Statehood: The Increasingly Important Role of Nongovernmental Organizations*, 5 IND. J. GLOBAL LEGAL STD. 191, 199 (1997). See also ALFRED VERDROSS & BRUNO SIMMA, UNIVERSELLES V. IKERRECHT 416 (1990); IAN BROWNLIE, PRINCIPLES OF PUBLIC INTERNATIONAL LAW 67-69 (1990).

53. Cf. Eric Dannemaier, *Democracy in Development: Toward a Legal Framework for the Americas*, 11 TUL. ENVTL. L.J. 1, 10 (1997).

54. Michael J. Schultheis, *Refugees in Africa: The Geopolitics of Forced Displacement*, 32 AFR. STUD. REV. 3, 29 (1989).

55. J. Samuel Barkin & Bruce Cronin, *The State and the Nation: Changing Norms and the Rules of Sovereignty in International Relations*, 48 INT'L ORG. 107, 130 (1994).

56. My use of the term "national" here corresponds with the European usage signifying a community brought together by real or imagined history, language and traditions. The literature on nations and nationalisms is bountiful. For definitions of "nations," see generally MONTERRAT GUIBERNAU, NATIONALISMS: THE NATION-STATE AND NATIONALISM IN THE TWENTIETH CENTURY (1996); Thomas M. Franck, *Clan and Superclan: Loyalty, Identity and Community in Law and Practice*, 90 AM. J. INT. L. 359 (1996); Lea Brilmayer, *The Moral Significance of Nationalism*, 71 NOTRE DAME L. REV. 7 (1995); John Hall, *Nationalisms, Classified and Explained*, in NOTIONS OF NATIONALISM 8 (Sukumar Periwal ed., 1995); DAVID MILLER, ON NATIONALITY (1995); ANTHONY D. SMITH, NATIONS AND NATIONALISM IN A GLOBAL ERA (1995); ERIC HOBBSBAWM, NATIONS AND NATIONALISM SINCE 1780 (1990); PETER ALTER, NATIONALISM (1989); BENEDICT ANDERSON, IMAGINED COMMUNITIES: REFLECTIONS ON THE ORIGIN AND SPREAD OF NATIONALISM (1983); ERNEST GELLNER, NATIONS AND NATIONALISM (1983); JOHN BREUILLY, NATIONALISM AND THE STATE (1982); *Definition and Classification of Minorities; Memorandum Submitted by the Secretary-General*, United Nations Commission on Human Rights, Subcommittee on Prevention of Discrimination and Protection of Minorities, U.N. Doc. E/CN.4/sub.2/85.27 (1949).

during the Cold War often reflected larger Cold War aims, these struggles are likely to concern secession, state formation, and intra-state powerplays.<sup>57</sup> States are often unable to control these conflicts.<sup>58</sup> Paramilitary troops and leaders of ethno-national political groups play a particularly potent role in the reshaped landscape; like NGOs, these non-state actors are unlikely to be held accountable under international law for human rights abuses.

In several of the recent conflicts, "mass population displacements have not been simply a consequence of armed conflict, but have also been the explicit objective of the warring parties."<sup>59</sup> Thus, "civilians are often used as weapons and targets in warfare, and large-scale displacements comprise a political strategy in claiming control over territory."<sup>60</sup> Although Cold War powers used population displacement in their ideological struggles, the promotion of intra-group hatred and forced movement of civilians in today's ethno-national conflicts is an end in itself. "Unable to gain external support for their cause by exploiting rival superpowers, governments and other actors alike have resorted to 'playing the communal card,' a process which has often cumulated in social violence and armed conflict."<sup>61</sup> Today's population movements are "unusually large and speedy."<sup>62</sup> They are often accomplished through gross human rights and humanitarian violations, including "conspicuous atrocity, systematic rape, hostage-taking, forced starvation and seige, the destruction of religious and historic monument, the use of shells and rockets against civilian targets . . . and the use of land-mines to make large areas uninhabitable."<sup>63</sup>

Where the state has "failed"<sup>64</sup> or "collapsed,"<sup>65</sup> the nature of the conflict is not political in the traditional sense. Often there is no central

57. See VALERY TISHKOV, ETHNICITY, NATIONALISM AND CONFLICT IN AND AFTER THE SOVIET UNION: THE MIND AFLAME 274 (1997).

58. See e.g., Ahmednasir M. Abdullah, *The Refugee Crisis in Africa as a Crisis of the Institution of the State*, 6 INT'L J. REFUGEE L. 562 (1994).

59. UNHCR, *supra* note 14, at 22; see also Frederick B. Baer, *International Refugees as Political Weapons*, 37 HARV. INT'L L.J. 243 (1996).

60. Gil Loescher, *The International Refugee Regime Stretched to the Limit?*, 47 J. INT'L AFF. 351, 363 (1994); see also GIL LOESCHER, REFUGEE MOVEMENTS AND INTERNATIONAL SECURITY 268 (1992).

61. UNHCR, *supra* note 9, at 25 (citing Human Rights Watch, *Playing the Communal Card: Communal Violence and Human Rights* (1995)).

62. UNHCR, *supra* note 14, at 23.

63. Mary Kaldor, *A Cosmopolitan Response to New Wars*, 8 PEACE REVIEW vol. 4 (1996); see also II HELSINKI WATCH, WAR CRIMES IN BOSNIA-HERZEGOVINA (1993).

64. Gerald B. Helman & Steven R. Ratner, *Saving Failed States*, 89 FOREIGN POL'Y 3, 20 (1992).

65. COLLAPSED STATES: THE DISINTEGRATION AND RESTORATION OF LEGITIMATE AUTHORITY (I. William Zartman ed., 1995).

authority to which peacemakers may appeal for a solution. It is very difficult for a country to get back on its feet without a strong international presence, including both military and humanitarian actors. That being said, the presence of international and regional entities, which are determined to re-member the state according to their own goals,<sup>66</sup> may contribute to the breakdown of sovereignty and to real and imagined state control. Large-scale displacements of people in the post-Cold War era have prompted individual state and regional organizations to intervene militarily in such countries as Albania, Iraq, Liberia, Somalia, and Yugoslavia.<sup>67</sup> "Whether such action is taken with or without the consent of the country concerned, and whether it is prompted by humanitarian or strategic considerations, it inevitably has an important impact on the local balance of political and military power."<sup>68</sup>

The shift to the post-Cold War refugee paradigm has occurred within the context of globalization, a complex phenomenon which pushes the refugee regime farther away from sole reliance on the state. Some of the trends witnessed by globalization include:

- Increased interdependence of states, specifically in the areas of trade and finance, security, technology and ecological problems, and other issues which contribute to the causes and solutions of uprootedness.<sup>69</sup>
- Increased interconnectedness of states and individuals, facilitated by improved communication technology and transportation, both of which break down the barriers between the "distant other" and us, bringing their problems back to us.<sup>70</sup>
- Greater access to and participation in international, regional, and national problem-solving by forces below the state, such as NGOs<sup>71</sup> and "new social movements with both local and

66. The Dayton Peace Plan for Bosnia-Herzegovina, for example, represents an attempt by the U.S. and other western powers to re-member Bosnia to suit their own goals. See Julie Mertus, Prospects for National Minorities under the Dayton Accords—Lessons from History: The Inter-War Minorities Schemes and the "Yugoslav Nations" (forthcoming book chapter 1997).

67. UNHCR, *supra* note 9, at 4.

68. *Id.*

69. See, e.g., TONY SPYBEY, *GLOBALIZATION AND WORLD SOCIETY* (1996).

70. There are fewer natural barriers to population movements today, thus facilitating long-distance border crossing. See David A. Martin, *The New Asylum Seekers, in THE NEW ASYLUM SEEKERS: REFUGEE LAW IN THE 1980'S* 8 (David A. Martin ed., 1988).

71. See, e.g., Felice D. Gaer, *Reality Check: Human Rights NGOs Confront Governments at the UN, in NGOs, THE UN, AND GLOBAL GOVERNANCE* 51–66 (Thomas G. Weiss & Leon Gordenker eds., 1996); Peter Shapiro, *New Global Communities: Nongovernmental Organizations in International Decision Making Institutions*, 18 WASH. Q. 48 (1995); THO-

transnational consciousness,"<sup>72</sup> and by other groups which may have an interest in issues related to humanitarian concerns.

- Greater access to and participation in international, regional, and national problems solving by forces above the state, such as transnational corporations, inter-governmental organizations, and regional collective arrangements.<sup>73</sup>
- Greater reliance on collective, transovereign solutions to international and civil armed conflict, human rights violations, natural and man-made ecological disasters (including ecological degradation)<sup>74</sup> and other factors that lead to and accompany population displacement.<sup>75</sup>
- Enhanced "cross linkages" among actors,<sup>76</sup> which allow individuals and NGOs direct access to NGOs in other states, and to regional and international systems and mechanisms.<sup>77</sup>

All of the above factors work to decentralize the state in the refugee regime and to elevate the role of other actors.

In this era of globalization there is "less deference by the international community and other participants in the international system to

MAS PRINCEN AND MATTHIAS FINGER, *ENVIRONMENTAL NGOS IN WORLD POLITICS* (1994); JOHN CLARK, *DEMOCRATIZING DEVELOPMENT: THE ROLE OF VOLUNTARY ORGANIZATIONS*, (1991).

72. JOSEPH A. CAMILLERI & JIM FALK, *THE END OF SOVEREIGNTY?* 3 (1992).

73. See Anthony G. McGrew, *Conceptualizing Global Politics, in GLOBAL POLITICS: GLOBALIZATION AND THE NATION STATE* 1, 1–30 (Anthony G. McGrew & Paul G. Lewis et al. eds., 1992).

74. See, e.g., Jessica B Cooper, *Environmental Refugees: Meeting the Requirements of the Refugee Definition*, 6 N.Y.U. ENVTL. L.J. 480 (1998).

75. Other factors may include political, economic and social restructuring in the countries of origin and/or on an international level which causes famine, joblessness, homelessness and other problems of survival.

76. The term "cross-linkages" is drawn from Chadwick F. Alger, *Local Responses to Global Intrusions, in GLOBALIZATION AND TERRITORIAL IDENTITIES* 77 (Zdravko Mlinar ed., 1992). One of the most successful examples of cross linkages is in the environmental arena. See, e.g., Ken Conca, *Greening the UN: Environmental Organizations and the UN System, in NGOs, THE UN, AND GLOBAL GOVERNANCE, supra* note 71, at 103–20; Maria Garner, Note, *Transnational Alignment of Nongovernmental Organizations for Global Environmental Action*, 23 VAND. J. TRANSNAT'L L. 1057, 1077 (1991). In the field of women's human rights, see, for example, Martha Alter Chen, *Engendering World Conferences: The International Women's Movement and the UN, in NGOs, THE UN, AND GLOBAL GOVERNANCE supra* note 71, at 139–58; Julie Mertus & Pamela Goldberg, *A Perspective on Women and International Human Rights After the Vienna Declaration: The Inside/Outside Construct*, 26 N.Y.U. J. INT'L L. & POL. 201 (1994).

77. See, e.g., Peter Sollis, *Partners in Development? The State, NGOs, and the UN in Central America, in NGOs, THE UN, AND GLOBAL GOVERNANCE, supra* note 71, at 139–58.. see also, Dianne Otto, *Nongovernmental Organizations in the United Nations System: The Emerging Role of International Civil Society*, 18 INT'L J. REFUGEE L. 107 (1996).

the mystique of state sovereignty and claims of domestic jurisdiction, and a greater willingness to assert and enforce broadly agreed international community policies, interests and values, such as those concerning human rights."<sup>78</sup> For the refugee regime, this means a greater willingness of international actors to interfere in events taking place within a country, especially when they present matters of humanitarian concern.<sup>79</sup> The behavior of actors in the post-Cold War paradigm thus becomes less "sovereignty-bound" and more "sovereignty-free."<sup>80</sup> Both traditional actors—states—and new actors—NGOs and other transsovereign forces—often act without regard to traditional notions of statehood.<sup>81</sup>

Refugee law and policy thus must adapt to a new environment in which states play a new and often less crucial role than they had played during the Cold War. It would be a mistake, however, to say that states have totally disappeared from the paradigm. As explained below, the refugee regime, and the organizations and entities that operate within it, still must pay heed to the wishes of states.

### B. The Post-Cold War Refugee Regime: A Soured Statist Paradigm

States still exercise great control over the needs of the uprooted. What do the uprooted want? In the immediate stage, "protection traditionally means life-saving interventions, fair treatment upon reception, compliance with essential humanitarian standards and non-return to a place of prospective persecution (non-refoulement)."<sup>82</sup> Later, however, they want something more: either a safe return home or the start of a new life.<sup>83</sup> Ultimately, they want the root cause of the problem addressed so that it never happens again.<sup>84</sup> In all three of these stages,

78. Richard B. Bilder, *Perspectives on Sovereignty in the Current Context: An American Viewpoint*, 20 CAN. U.S.L.J. 9, 16 (1994).

79. UNHCR recognizes that the decline of sovereignty is less clear when military intervention is concerned. UNHCR, *supra* note 14, at 39.

80. This terminology is drawn from Leon Gordenker and Thomas Weiss, *Pluralizing Global Governance: Analytic Approaches and Dimensions*, 16 THIRD W. Q. 357, 360 (1995).

81. See e.g., Arthur C. Helton, *The Legality of Providing Humanitarian Assistance Without the Consent of the Sovereign*, 4 INT'L J. REFUGEE L. 373 (1992).

82. Arthur C. Helton, *UNHCR and Protection in the 90s*, 6 INT'L J. REFUGEE L. 1, 1-2 (1994); see also NORMAN MYERS, ENVIRONMENTAL REFUGEES 150 (1995).

83. See JULIE MERTUS ET AL., THE SUITCASE: REFUGEE VOICES FROM BOSNIA AND CROATIA (1997); RECONSTRUCTING LIVES, RECAPTURING MEANING: REFUGEE IDENTITY, GENDER AND CULTURE CHANGE (Linda A. Cimio & Ruth M. Kruffeld eds., 1994).

84. See Samuel O. Gyandoh, Jr., *Human Rights and Governance in Africa*, 10 TEMPLE INT'L & COMP. L.J. 265 (1996) (reviewing the statement "[w]hether or not most of them would be able to phrase it in our legal terminology, African refugees want their human rights restored in their host countries.").

addressing the needs of the uprooted entails the protection and promotion of human rights. For example, the rights to life and freedom from violence are often threatened during flight, in refugee camps, upon resettlement to a third country, and upon return to the home country. Under the current refugee regime, the state is still necessary for addressing such human rights concerns. States increasingly cannot or will not free themselves to do so, and non-state actors make attempts with varying degrees of success.<sup>85</sup>

As a rule, the greater the state involvement with uprooted persons, the more rights potentially become available.<sup>86</sup> Uprooted people in a refugee camp or "safe areas" have few rights, *de jure* or *de facto*. They may not be able to travel, to work, to be educated, or to reunite with their family members. Although an international body can provide an uprooted person with "temporary protection" in a refugee camp in the middle of nowhere (or in an area in conflict), only a state can grant asylum and the rights necessary to start life anew. The 1967 United Nations Declaration on Territorial Asylum recognized that when a state grants asylum, it is exercising its sovereignty.<sup>87</sup> Adhering to this definition of sovereignty, states maintain a resolute grip over asylum decisions. As Eduardo Arboleda and Ian Hoy observe, states are unlikely to relinquish control over these matters: "Whether we like it or not, it is not to be expected that states will enter into an agreement that would eliminate their right to determine whom they admit within their borders."<sup>88</sup>

In terms of their legal status and rights under domestic and international law, distinctions can be drawn among the internally displaced, retirees, asylum seekers, and stateless people. "[I]n terms of their human needs and the humanitarian issues associated with their plight, . . . [these groups] share a number of important characteristics."<sup>89</sup> States refuse to relinquish their right to make legal status determinations, but at the same time, states shrink from their responsibility to address such determinations as human needs of the uprooted. This dilemma is drawn out in three interrelated areas: state refusal to grant asylum; the international community's move from protection to containment; and the move of

85. See, e.g., HUMAN RIGHTS WATCH, UNCERTAIN REFUGEE: INTERNATIONAL FAILURES TO PROTECT REFUGEES, Report 9/1, (1997).

86. I am indebted to Pamela Goldberg for this formulation.

87. ÅTLE GRAHL-MADSEN, TERRITORIAL ASYLUM 12-13 (1980); see Joan Fitzpatrick, *Flight from Asylum: Trend Toward Temporary "Refuge" and Local Responses to Forced Migrations*, VA. J. INT'L L. 13 (1994).

88. Eduardo Arboleda & Ian Hoy, *The Convention Refugee Definition in the West: Disharmony of Interpretation and Application*, 5 INT'L J. OF REFUGEE L. 66, 89 (1993).

89. UNHCR, *supra* note 14, at 6.

states and the international community from durable to temporary solutions. Each of these will be considered in turn.

### 1. State Refusal to Grant Asylum

Western countries view today's uprooted as burdens to avoid, not as populations to be welcomed. Unlike the Cold War refugees, these new arrivals are nonstrategic. B.S. Chimni draws the connection directly, "with the end of the Cold War the firm basis of interest in refugees, particularly from the developing world, has been removed: refugees no longer have ideological or geopolitical value."<sup>90</sup> Would-be receiving states face economic declines and rising xenophobia, racism, anti-Semitism, and nativism.<sup>91</sup> In closing their borders, states are concerned about the economic burden of new arrivals and the ways in which they will exacerbate already existing racial, ethnic, and national tensions.

Not surprisingly, while the number of asylum-seekers has skyrocketed over the past ten years, fewer and fewer of the uprooted successfully navigate the asylum process. The number of asylum seekers in Europe, North America, and Australia increased from 90,444 in 1983 to over 825,000 ten years later.<sup>92</sup> Between ten and twenty percent of all asylum seekers in Europe are accepted, a decrease from fifty percent in the mid-1980s.<sup>93</sup>

90. B.S. Chimni, *The Meaning of Words and the Role of UNHCR in Voluntary Repatriation*, 5 INT'L J. REFUGEE L. 443, 444 (1993).

91. For a discussion of nativism and the rise of the new right in Europe, see, for example, THE FAR RIGHT IN WESTERN AND EASTERN EUROPE (Luciano Cheles et al. eds., 1995); TOMISLAV ŠUNIĆ, AGAINST DEMOCRACY AND EQUALITY: THE EUROPEAN NEW RIGHT (1990); HERMANN KURTHEN ET AL., ANTISEMITISM AND XENOPHOBIA IN GERMANY AFTER UNIFICATION (1997); NEW XENOPHOBIA IN EUROPE (Bernd Baumgartl & Adrian Favel eds., 1995); FASCIST EUROPE: THE RISE OF RACISM AND XENOPHOBIA (Glyn Ford ed., 1992).

92. Charles B. Keely & Sharon Stanton Russell, *Responses of Industrialized Countries to Asylum Seekers*, 47 J. INT'L AFF. 399 (1994).

93. MARK GIBNEY, *Refugees and Immigrants in the New Europe*, in HUMAN RIGHTS IN THE NEW EUROPE: PROBLEMS AND PROGRESS 157, 160 (David Forsythe ed., 1994); see also JOHAN CELS, *Responses of European States to De Facto Refugees*, in REFUGEES AND INTERNATIONAL RELATIONS 187 (Gil Loescher & Laila Monahan eds., 1990); Colleen V. Thouz, *New Directions in Refugee Protection*, 22 FLETCHER F. OF WORLD AFF. 89, 92 (1998) ("Germany in 1993 modified what had been Europe's most generous asylum laws to reduce the number of refugees seeking asylum. Public pressure and high unemployment levels are leading to changes in the law to deny asylum-seekers the right to work in Germany, for instance, while their claim is being processed"); *Foreign Asylum Seekers in Germany Decline*, DEUTSCHE PRESSE AGENTUR, Apr. 4, 1996 (noticing that the tightening of restrictions led to a sixty percent decline in the number of refugees seeking political asylum in Germany between 1993 and 1994 and that in 1995, the successful asylum application rate was only nine percent).

Denial for asylum can take three forms.<sup>94</sup> First, would-be receiving states can undertake direct measures aimed at preventing specific groups of people from crossing borders.<sup>95</sup> States may physically turn asylum-seekers back before they cross the frontier,<sup>96</sup> or detain them outside state territory where domestic laws and human rights standards may not be applicable, as some have unconvincingly argued.<sup>97</sup> Second, states can implement indirect measures that make crossing the border more difficult, such as visa requirements,<sup>98</sup> carrier sanctions,<sup>99</sup> and the granting of great discretion to border guards. In her exhaustive study of such procedures in Western Europe, Maryellen Fullerton notes that this latter factor is quite significant as the "snap decisions of border guards and airline personnel are virtually unreviewable."<sup>100</sup> Raising due process concerns she notes:

The lack of an adequate record of the initial decision, the inability to obtain legal assistance, and the time pressures that prevent gathering evidence to support further the asylum-seeker's claim ensure that any appeal that is permitted fails to provide a meaningful opportunity for review.... Such inadequate and unfair procedures necessarily will result in a number of erroneous decisions.<sup>101</sup>

94. See Subrata Roy Chowdhury, *A Response to the Refugee Problems in Post Cold War Era: Some Existing and Emerging Norms of International Law*, 7 INT'L J. REFUGEE L. 100, 102 (1995).

95. See, e.g., Thouz, *supra* note 93, at 89-90 ("Western receiving states are adopting highly restrictive measures to curtail and, to a large extent, restrict the future entry of refugees and asylum-seekers.... Significant trends in migration policy include highly restrictive measures being implemented both at the national and inter-governmental levels, and the general recognition that temporary asylum in the past leads to permanent settlement in the future").

96. One infamous recent example of this is the U.S. coast guard summarily turning back boats of refugees from Haiti. See Robert Maguire et al., *Haiti Held Hostage: International Responses to the Quest for Nationhood 1986 to 1996*, Thomas J. Watson Institute for International Studies and the United Nations University, Occasional Paper #23 (1996).

97. I say "not considered to be" because some commentators (including myself) would argue that some basic human rights standards are always applicable. See Chowdhury, *supra* note 94, at 100.

98. For example, all EU states imposed a visa requirement on would-be refugees from Bosnia and Serbia. See Jacqueline Bhabha, *European Harmonization of Asylum Policy: A Flawed Process*, 35 VA. J. INT'L L. 101, 105 (1994).

99. See Erika Feller, *Carrier Sanctions and International Law*, 1 INT'L J. REFUGEE L. 48, 66 (1989).

100. Maryellen Fullerton, *Restricting the Flow of Asylum Seekers in Belgium, Denmark, the Federal Republic of Germany, and the Netherlands: New Challenges to the Geneva Convention Relating to the Status of Refugees and the European Convention on Human Rights*, 29 VA. J. INT'L L. 33, 113 (1988).

101. *Id.*

Finally, in order to dissuade refugees from advancing upon their borders, states may lower the standards of treatment for refugees within the host country. For example, states routinely deny refugees the right to work, to education, housing and social welfare, as well as their right to family reunification.<sup>102</sup>

For the tightly packed Western European states, "there has been something akin to a 'trump thy neighbor' phenomenon because nations do not want to appear to have asylum procedures and policies that are perceived by asylum seekers to be more liberal than those of other states, and that might then serve to attract additional migrants."<sup>103</sup> States have used bilateral and multilateral agreements as mechanisms for dealing with the unwanted flow of asylum seekers. For example, Germany has negotiated agreements with Poland and Hungary permitting rejection of asylum applicants at the border if they have passed through a "safe country," defined as "a country that has an asylum process that meets international standards and is not itself a source of asylum seekers."<sup>104</sup> Other European Agreements designed to specify strict rules for adjudicating asylum applications include the Dublin Convention and The Convention Applying the Schengen Agreement.<sup>105</sup>

Such international and regional arrangements<sup>106</sup> on asylum policy have not triggered a turn away from state sovereignty. Jacqueline Bhabha noted with respect to European harmonization of refugee policy that "[g]enerally, agreement and meaningful steps toward common policy have only occurred in the piecemeal adoption of restrictive measures

102. See Goodwin-Gill, *supra* note 11, at 8.

[T]he Convention's capacity for narrow or restrictive interpretation in the highly structured environments of case by case adjudication leaves thousands "outside" or "beyond" protection. They become the objects of ad hoc, discretionary and extra-legal policies that finally benefit no one. Individuals are commonly denied even basic rights, or any opportunity to contribute to their own solution.

*Id.*; see also Chowdhury, *supra* note 94, at 102.

103. Gibney, *supra* note 93, at 162.

104. Charles B. Keely & Sharon Stanton Russell, *Responses of Industrialized Countries to Asylum Seekers*, 47 *J. INT'L AFF.* 399, 405 (1994); see Alberto Achermann & Mario Gattiker, *Safe Third Countries: European Developments*, 7 *INT'L J. REFUGEE L.* 19 (1995); Eva Kjaergaard, *The Concept of "Safe Third Country" in Contemporary European Refugee Law*, 6 *INT'L J. REFUGEE L.* 649, 650-51 (1994).

105. The Convention Determining the State Responsibility for Examining Applications for Asylum Lodged in One of the Member States of the European Community [the Dublin Convention] was signed on June 15, 1990 by twelve members of the European Community. The Convention Applying the Schengen Agreement was signed by nine E.C. countries in 1985 and implemented on March 26, 1995. See Gerald L. Neuman, *Buffer Zones Against Refugees: Dublin, Schengen, and the German Asylum Agreement*, 33 *VA. J. INT'L L.* 503, 506 (1993). See generally Alberto Achermann & Mario Gattiker, *Safe Third Countries: European Developments*, 7 *INT'L J. REFUGEE L.* 19 (1995).

106. See Bhabha, *supra* note 98, at 101.

which have involved no ceding of sovereignty or reduction in powers of control."<sup>107</sup> Even after these agreements, there is neither a uniform definition of refugee, nor a common set of procedures for processing applications or for instituting appeal rights within Europe.<sup>108</sup> Far from indicating an abrogation of sovereignty, these agreements indicate the persistence of states' practice of restricting asylum.

## 2. The International Community's Move from Protection to Containment

The international community has conspired with powerful would-be receiving states against the uprooted by tacitly joining the campaign against asylum seekers in Europe.<sup>109</sup> For example, Germany and its neighbors are allies in the "Fortress Europe" by coordinating their restrictive policies against refugees.<sup>110</sup> Instead of emphasizing protection of the uprooted, the international community now trumpets containment—the localization of the problem and restriction of the flow of humanity. The trend toward localization is evident in numerous responses which attempt to keep would-be refugees within their country of origin or neatly packed into border areas of the international countries' own choosing. Interestingly, the UNHCR has made a concerted effort to frame its new policy in terms of an effort to address the root cause of population flows.<sup>111</sup> In 1992, the High Commissioner declared:

There now exists an urgent need to explore new, complementary protection strategies . . . that . . . rest on activities principally in the fields of prevention and solutions to refugee problems and depend on an early clarification of the parameters of UNHCR's involvement, particularly inside the country of origin.<sup>112</sup>

107. *Id.*

108. *Id.* at 109.

109. LAWYERS COMMITTEE FOR HUMAN RIGHTS, UNHCR AT 40: REFUGEE PROTECTION AT THE CROSSROADS 129 (1991); see also Thouez, *supra* note 93, at 89.

110. *Id.* at 90.

111. See The Office of the United Nations High Commissioner for Refugees, Inter-Office Memorandum, No. 78/92, *The Report of the UNHCR Working Group on International Protection* (Geneva: UNHCR, July 31, 1992).

112. *Note on International Protection*, Submitted by the High Commissioner to the 43rd Sess. of the Executive Committee of the High Commissioner's Programme, U.N. Doc. A/JAC.96/799 ¶ 5 (1992), reprinted in 4 *INT'L J. REFUGEE L.* 563 (1992).

In practice, the UNHCR's policy has less to do with root causes than it does with keeping refugees in their place—that is, far from the borders of would-be receiving states in the Western world.<sup>113</sup>

Rather than creating new options for uprooted persons, the new focus on containment has served to prevent them from meeting their needs. The case of Bosnia exemplifies the way in which the UNHCR program of "humanitarian action" limited opportunities for the uprooted while nevertheless supporting would-be receiving states' non-admission policies.<sup>114</sup> One example of this, Guy Goodwin-Gill suggests, is the UNHCR facilitation of persons leaving Bosnia and passing through the sector of Krajina [then Serb controlled] into Croatia proper:

The tight control over departures, coupled with the extent of organization and the emphasis of documentation, meant that there was *no* spontaneous movement of persons in search of refuge. Clearly, many who wanted or needed to leave Bosnia never made it to the crossing point at the Stara Gradiska bridge. Here, UNHCR's involvement served as tacit endorsement of "organized flight," undermining the individual right to seek asylum, by effectively limiting the opportunities for exit.<sup>115</sup>

For the uprooted, the UNHCR's self-declared "humanitarianism" limits choices of exit, restricts rights to movement, and creates roadblocks to starting a new life in a new land when conditions back home are too unsafe to return.

With its blessing, the international community now regards human "holding zones" as an acceptable alternative to traditional protection. For example, when Turkey refused asylum to thousands of Kurds after the Persian-Gulf war, the international community reacted by moving the Kurds into a U.N.-protected zone in Iraq.<sup>116</sup> While the international community did not condemn Turkey for failing to abide by its sovereign responsibilities to grant a right to seek asylum, the international community did instruct Iraq to allow immediate access to international humanitarian organizations. Although Iraq initially objected to the

113. Andrew Shacknove makes this distinction between programs to address root causes and containment. Andrew Shacknove, *From Asylum to Containment*, 5 INT'L J. REFUGEE L. 516 (1993).

114. See M. Barutcski, *The Reinforcement of Non-Admission Policies and the Subversion of UNHCR: Displacement and Internal Assistance in Bosnia-Herzegovina (1992-94)*, 8 INT'L J. REFUGEE L. 49 (1996).

115. Guy Goodwin-Gill, *Refugee Identity and the Fading Prospect of International Protection* (1996) (conference paper on file with author).

116. See Michael E. Harrington, *Operation Provide Comfort: A Perspective in International Law*, 8 CONN. J. INT. L. 635 (1993); Howard Adelman, *Humanitarian Intervention: The Case of the Kurds*, 4 INT'L J. REFUGEE L. 1, 4-5 (1992).

measure as a violation of its sovereignty, it eventually concluded a Memorandum of Understanding authorizing U.N. access to the "safe havens"<sup>117</sup>—a predecessor to the "safe havens" that failed to protect displaced people in Bosnia-Herzegovina.<sup>118</sup> In Bosnia, "safe havens" were kept under siege by combatants and manipulated by the warring factions for their long and short term needs.

Similarly, "secondary states" are rapidly becoming popular as holding reservoirs for those to whom the U.S. and Western Europe have closed their gates. Apart from the simple desire to keep the uprooted out of their own domestic arena, some would-be receiving states have a strategic interest in keeping them close to their country of origin. Many uprooted individuals, by merely belonging to one ethnic/national group or another, are linked to the political struggles that caused them to flee. Just as the warring parties used for their own gain the displacement of people, the international community uses for their own ends the containment of people.<sup>119</sup>

Donor governments may also have a vested interest in when and how refugee populations return. In some cases, donor governments prefer that the flight causing conflict not end too soon. They would prefer a victory for the side favored by the donor government, or at least humiliation and devastation for the side(s) disparaged by the donor.<sup>120</sup> Dennis Gallagher explains this phenomenon by way of example:

Western powers wished to prolong the debilitating effects of the communist-led Eritrean and Tigrean liberation struggles over the Ethiopian government, although they did not care whether these movements ultimately succeeded. Donor governments supported refugee programs in neighboring Sudan that provided safe havens for large numbers of Eritreans and Tigreans. Governments, on a clandestine basis, also secretly provided the

117. HELENA COOK, *THE SAFE HAVEN IN NORTHERN IRAQ: INTERNATIONAL RESPONSIBILITY FOR IRAQI KURDISTAN* (1995).

118. See LARRY MINEAR ET AL., *HUMANITARIAN ACTION IN THE FORMER YUGOSLAVIA: THE U.N.'S ROLE, 1991-1993* (Providence, RI: Thomas J. Watson, Jr. Institute for International Studies; Washington, DC: Refugee Policy Group 1994); AGE EKNES, *BLUE HELMETS IN A BLOWN MISSION?: UNPROFOR IN FORMER YUGOSLAVIA* (Norwegian Institute of International Affairs, ed., 1993).

119. UNHCR, *supra* note 14, at 37 (citing the examples of the Nicaraguan Contras in Honduras, the Afghan mujahideen in Pakistan, and the Namibian exiles in Angola).

120. The sides include not only the warring parties but also their supporters. Western governments were most interested in delivering aid to refugees from Afghanistan as long as the Soviet Union was directly or indirectly involved in the war. "At the very least, they were interested in making the USSR pay as much as possible—militarily, politically and financially—for the occupation." Dennis Gallagher, *Durable Solutions in a New Political Era*, 47 INT'L AFF. 433 (1994).

humanitarian arms of these liberation movements with relief aid, which was transported, from Sudan into Eritrean- and Tigrayan-controlled areas of Ethiopia.<sup>121</sup>

In like manner, donor governments can use refugee camps in border areas as camouflage for providing "their side" with aid. Although similar manipulation of refugee populations occurred during the Cold War, today it is less clear who is supporting guerrilla groups in refugee camps and why.<sup>122</sup>

Thus, the retreat from protectionism not only helps states avoid an influx of unwanted peoples, but it also serves their strategic purposes. By supporting containment, the international community aids would-be receiving states in achieving their goals. For refugees, however, in-country protection and border-area holding camps are no solution.<sup>123</sup> "[T]hose people who attempt to take refuge in a neighbouring or nearby state increasingly find that they simply swapped one situation of insecurity with another."<sup>124</sup>

### 3. From Durable Solutions to a Temporary Arrangement or Repatriation

Three "durable solutions" to refugee crises are usually considered: voluntary repatriation, local integration into the country of asylum, and resettlement in a third country. With the doors of would-be receiving states tightly closed, attention has turned to imposed re-settlement in near-by countries and, in particular, to financial contributions to "first asylum" states (meaning, keeping African refugees in near-by African countries).<sup>125</sup> Alternatively, if the refugees have made it to Western countries, the goal becomes a temporary arrangement and/or the repatriation of refugees.

The vast majority of those denied refugee status under the 1951 Refugee Convention are allowed to remain in host states on humanitar-

121. *Id.* See also GAIM KIBREAB, *REFUGEES AND DEVELOPMENT IN AFRICA: THE CASE OF ERITREA* (1987).

122. For the ways in which humanitarian aid can exacerbate conflicts, see MICHAEL MAREN, *THE ROAD TO HELL: THE RAVAGING EFFECTS OF FOREIGN AID AND INTERNATIONAL CHARITY* (1997); JOHN PRENDERGAST, *FRONTLINE DIPLOMACY: HUMANITARIAN AID AND CONFLICT IN AFRICA* (1996).

123. Cf. James C. Hathaway, *New Directions to Avoid Hard Problems: The Distortion of the Palliative Role of Refugee Protection*, 8 J. REFUGEE STUD. 288, 292 (1995).

124. UNHCR, *supra* note 9, at 5.

125. Given space limitations, this option is not discussed here. See B.E. HARRELL-BOND, *IMPOSING AID: EMERGENCY ASSISTANCE TO REFUGEES* 27 (1986) (demonstrating that "while human societies everywhere are able to adapt, and that migration and resettlement may be one method, the imposition of these solutions, denying as it does fundamental human rights, create more problems than they solve.").

ian grounds,<sup>126</sup> and are thereby granted a status known variously as "leave to remain" or "humanitarian status."<sup>127</sup> However, conflicting messages are sent to asylum seekers and the asylum-providing public. The denial of asylum applications sends a message to the general public that the claims made by the new arrivals are not warranted; that these people do not have a well-founded fear of persecution, they just want to improve their lives.<sup>128</sup> The message to would-be asylum-seekers is that one must simply make it over the border, as the country will be reluctant to return them once they arrive.<sup>129</sup>

Given state reluctance to grant asylum, various forms of temporary protection have become "the link between *non-refoulement* [the obligation to not send those in flight back to a place in which they would be endangered] and a durable solution."<sup>130</sup> There are three purposes behind temporary protection:

- (1) To save administrative and economic resources through the absence of a full asylum procedure assessing individual claims, but applying a *prima facie* group determination.
- (2) Politically it becomes easier to return the refugee if the situation in the country of origin changes, for then it is not a question of withdrawing a residence permit but rather of not renewing it. In this way, a state sends a signal to the refugee that his or her stay in the specific country is only temporary.
- (3) Finally, the state sends a signal to the public at large that this refugee situation is purely a matter of protection with no elements of voluntary migration.<sup>131</sup>

All of these purposes serve the interests of the receiving countries while neglecting the needs of the uprooted. The uprooted cannot last in a holding pattern forever. After a while, they want to get on with their lives, to return home, or start a new life in a new country. Temporary protection denies these needs.

The goal of temporary protection is to treat the uprooted minimally well, lest they cause civil unrest in their new country, but not too well, so that they "keep[] his or her mind open to the possibility of returning

126. See LAWYERS COMMITTEE FOR HUMAN RIGHTS, *supra* note 109, at 121.

127. GIBNEY, *supra* note 93, at 157, 160; see also Johan Cels, *Responses of European States to De Facto Refugees*, in *REFUGEES AND INTERNATIONAL RELATIONS* (Gil Loescher & Laila Monahan eds., 1989).

128. Deborah Anker, *Mischaracterized Asylum Crisis Lydio*, in 19 IN DEFENSE OF THE ALIEN 149, 150 (Lydio F. Tomasi ed., 1997).

129. *Id.*

130. Morten Kjaerum, *Temporary Protection in Europe in the 1990s*, 6 INT'L J. REFUGEE L. 444, 445 (1994).

131. *Id.* at 449-50.

home."<sup>132</sup> The ways in which governments prevent the temporarily protected from becoming *too comfortable* varies from country to country. In particular, the right to work and the right to family reunion, access to education, and the amount of social and relief payments may differ from that accorded to other foreigners in the country. Moreover, no country will issue travel documents to those under temporary protection.<sup>133</sup>

After or instead of temporary protection, many states seek to repatriate refugees, often with the assistance of the UNHCR. Since the 1980s, the UNHCR has recognized "voluntary repatriation as the preferred solution to refugee problems."<sup>134</sup> This often boils down to returning refugees into areas still in conflict.<sup>135</sup> These practices threaten to violate the principle of *non-refoulement*.<sup>136</sup> The pre-conditions for the participation of the U.N., states, or other actors in voluntary repatriation should include such factors as "fundamental change of circumstances, voluntary nature of the decision to return, tripartite agreements between the state of origin, the host state and UNHCR, and return in safety and dignity."<sup>137</sup> Above all, this means that participants in voluntary repatriation should not return refugees if their fundamental human rights are endangered.<sup>138</sup> States often attempt to rush refugees back home before they meet these conditions.<sup>139</sup> The return of refugees from Haiti,<sup>140</sup> the

132. *Id.* at 447.

133. *Id.* at 451. See UNHCR and the Danish Ministry of the Interior, *Survey of Implementation of Temporary Protection, Comprehensive Response to the Humanitarian Crisis in the Former Yugoslavia*, July 16, 1993.

134. UNHCR, *supra* note 14, at 31 (1995). In the beginning, the UNHCR's approach continued to concentrate . . . in countries of asylum: registering potential returnees, verifying that their departure was genuinely voluntary and arranging their transport home. Once they had crossed the border into their homeland, they were considered to be the responsibility of their own state and therefore ceased to be of international concern.

*Id.* Today, the UNHCR's focus on repatriation purportedly carries the concern with containment back into the country of origin.

135. See Barry Stein & Fred Cuny, *Repatriation Under Conflict*, in 1991 WORLD REFUGEE SURVEY 15-21 (1991).

136. Guy Goodwin-Gill has called non-refoulement one of the "soundest rules" of the international system for the protection of refugees. See, e.g., Goodwin-Gill, *supra* note 11.

137. B.S. Chimni, *The Meaning of Words and the Role of UNHCR in Voluntary Repatriation*, 5 INT'L J. REFUGEE L. 442, 448 (1993).

138. For an application of this principle, see UNHCR HANDBOOK, VOLUNTARY REPATRIATION: INTERNATIONAL PROTECTION (1996).

139. Goodwin-Gill observes that "[a]lready in western Europe, there are plenty of documented returns of individuals to countries with a present record of extensive human rights violations, such as Iran, Bosnia, Turkey, Algeria, Nigeria, and Zaire. . . ." Goodwin-Gill, *Refuge Identity and the Fading Prospect of International Protection* (1996) (conference paper on file with author).

140. See Lawyers Committee for Human Rights, *Refugee Refoulement: The Forced Return of Haitians Under the U.S.-Haitian Interdiction Agreement* 58 (1990).

Great Lakes Region,<sup>141</sup> and Burma<sup>142</sup> are only three recent illustrations of situations in which the international community forced refugees home before conditions had become safe for their return.<sup>143</sup>

By failing to provide adequate protection for refugees—and, in particular, by making the conditions of temporary protection miserably inadequate—states also indirectly send refugees home. "Why would adequately protected and nourished refugees return home during conflict conditions to a country ruled by the government that originally caused the flight?"<sup>144</sup> The primary cause of so-called "voluntary repatriation" is the host state's unwillingness to provide for and protect refugees.

States, the UNHCR, and other international actors work together in the move from durable to temporary solutions. States come out as winners in the process: above all, states retain control over their borders. For the uprooted, however, temporary protection and a quick return home are not effective solutions by any means. Refugees forcibly returned to their homes in conflict zones in Burundi, Sudan, or Kosovo, for example, are all likely to be confronted with threats to their fundamental human rights. By uncovering a limited yet tenacious role for the state, the post Cold-War paradigm shift in the refugee regime does not resolve such problems, rather this paradigm shift merely changes the field in which human rights advocates can fashion responses.

#### CONCLUSION: NEW QUESTIONS

Today's refugee regime is paradoxically part of the globalization process and an exception to this process. At first glance, the shift from a Cold War to a post-Cold War refugee regime appears to signify a move away from the state. The role of the state mutates and diminishes with the entry of new non-state actors into the international arena, including powerful NGOs. For example, states and international actors enhance

141. See, e.g., Amnesty International, *Great Lakes Region Still in Need of Protection: Repatriation, Refoulement and the Safety of Refugees and the Internally Displaced*, Jan. 24, 1997, AI Index AFR 02/07/97.

142. See K. LAMBRECHT, *THE RETURN OF ROHINGYA REFUGEES TO BURMA: VOLUNTARY REPATRIATION OR REFOULEMENT?* (1995).

143. See Human Rights Watch, *Discussion Paper: Protection in the Decade of Voluntary Repatriation*, Sept. 20, 1996; Guy S. Goodwin-Gill, *The Haitian Refoulement Case: A Comment*, 6 INT'L J. OF REFUGEE L. 103 (1994); Thomas David Jones, *The Haitian Refugee Crisis: A Quest for Human Rights*, 15 MICH. J. INT'L L. 77 (1993).

144. Barry N. Stein and Frederick C. Cuny, *Repatriation in a Civil War/Conflict Situation*, paper presented at Roundtable Consultation on Voluntary Repatriation and UNHCR, Geneva, Switzerland, June 2-3, 1993, at 3.

their willingness to work with these new actors in reaching collective solutions. Secessionist wars break out, and states have little control over the combatants. In addition, international bodies increase their willingness to offer aid regardless of state boundaries or state ideologies. Nonetheless, the persistence of the statist paradigm in the asylum context casts a shadow over the possibilities for a post-Cold War refugee regime.

Without the will of states, NGOs and collective problem-solving can only do so much for the uprooted. States still hold the key to asylum and to permanent, durable solutions. It only follows that states are most often essential actors in efforts to protect the human rights of the uprooted. Yet would-be receiving states have sealed their borders shut, and the international community, notably the UNHCR, has conspired with states to offer "first country" resettlement, "safe areas," temporary protection, and repatriation as alternatives to asylum. For most of the uprooted, however, such alternatives do not address their long-term problems. The shift away from protection and asylum and toward containment and prevention re-shapes the way in which we define who is aid-worthy. As Bill Frelick observes, "a new paradigm is emerging by which refugee flows are prevented before asylum seekers cross an international border, the definitional trip-wire that heretofore has marked the threshold step in the world's response to refugees."<sup>145</sup> At the same time, the Cold War's demise has re-shaped donor states' definition of those worthy of assistance: states are more willing to offer aid based not on ideology, but rather on need. This need concerns their own self-interest as well as the interests of refugees. This disturbing shift may be detrimental to the protection and promotion of the human rights of the vast majority of today's uprooted populations.

Within this new paradigm, transsovereign forces must find a way to address the needs of the uprooted when states fail to do so. This means navigating between what states are willing to give up and what they have refused to relinquish. How can the international community turn this situation into an opportunity for meeting refugee needs? Increased involvement of refugee-led, non-governmental projects; enhanced participation of human rights groups in humanitarian concerns; and enhanced work of other non-state actors are a good place to start. In developing responses we must remember that states are unlikely to give up their hold on asylum decisions anytime soon. When do non-state actors need to interact with states, and when can they work on their own? How can non-state actors interact with the state to achieve their own goals?

145. Bill Frelick, *Preventing Refugee Flows: Protection or Peril?*, 1993 WORLD REFUGEE SURVEY 5 (1993).

These are the kinds of questions that must be considered in the new era if the human rights of the uprooted are to be taken seriously.

CHART A: SUMMARY OF PARADIGM SHIFTS

<i>Cause of Uprootedness</i>	<i>Cold War, Colonialist, Paradigm</i> conflict between states liberation movements deprivation, violation of human rights, persecution by state population displacement manipulated by cold warriors	<i>Post-Cold War Post-Colonialist Paradigm</i> conflict within states breakdown of states deprivation, violation of human rights, persecution by state and non-state entities population displacement manipulated by internal warriors	<i>Nature of Change in State Paradigm</i> ▲ state linked to causation increasingly by its failures and not by its actions ▲ warring parties not necessarily linked to state entities ▲ increase in abuses and deprivations by non-state forces
<i>Criteria for Rescue/Aid/Asylum</i>	ideological and geopolitical grounds rescue to favored political camps image of rescuer to opponents activists and targets of persecution who have moved across state boundaries	racial, ethnic and national prejudices mercy to individuals image of rescuer to general public activists, targets and victims of persecution, deprivation and human rights abuses	▲ favoritism of state plays a role in rescue/asylum/aid decision, but nature of favoritism changes ▲ state becomes increasingly concerned about its image vis-à-vis needy individuals ▲ state boundaries of diminishing importance

CHART A: SUMMARY OF PARADIGM SHIFTS (CONTINUED)

<i>Direction of Protection</i>	<i>Cold War, Colonialist, Paradigm</i> facilitate right to asylum safety provided in host country meet immediate humanitarian needs of refugees (outside country of origin) and safeguard their human rights	<i>Post-Cold War Post-Colonialist Paradigm</i> "preventative protection" head off and stem refugee flow safety provided in "safe areas" within country or in border areas meet immediate humanitarian needs of uprooted within and outside country of origin and improve general human rights conditions	<i>Nature of Change in State Paradigm</i> ▲ movement from protection strategies to containment strategies ▲ place of protection no longer dependant on state boundaries ▲ actors above and below states (IGOs and NGOs) play increasing role in meeting needs
<i>Direction of Durable Solutions</i>	asylum integration into host country voluntary repatriation	facilitated/promoted return improvement of human rights/democracy/develop- ment in country of origin temporary protection as interim solution/asylum and integration only in rare circumstances	▲ locus of durable solutions increasingly located in country of origin ▲ states still necessary for durable solutions but final outcome shifts away from asylum

CHART A: SUMMARY OF PARADIGM SHIFTS (CONTINUED)

<i>Focus of Rights Talk</i>	<i>Cold War, Colonialist, Paradigm</i>	<i>Post-Cold War Post-Colonialist Paradigm</i>	<i>Nature of Change in State Paradigm</i>
	<p>Right of refugees to: seek asylum non-refoulement human rights</p> <p>Right of international communities to: protect their definition of human rights</p>	<p>Right of refugees to: temporary protection repatriation human rights/democracy/ development</p> <p>Right of "international community" to: guard against dangers to the peace</p> <p>Right of host countries to: protect their own culture</p>	<p>▲ focus of rights increasingly on non-state entities</p> <p>▲ enforcement of such rights increasingly lies in the hands of regional and international collective mechanisms and NGOs</p> <p>▲ to the extent that rights are focused on states, they are increasingly on the would-be receiving state</p>